

Your Unique™

Guide to Fit

Version 3

Dear Client:

Welcome to Unique! We are delighted to have you as a Client and are looking forward to having a great relationship together!

This newsletter will introduce you to Unique and give you some guidance and advice that will help you get the best possible results from your Unique custom-fit experience.

You'll learn about body shapes and how to choose your patterns, how to understand the amount of ease you like in your clothes, why our patterns have darts and why fabric fitting is so important.

Our goal is to provide you with custom-fit patterns so you can make the most of your sewing experience.

Pull up a cozy chair and relax while you read

through the great information the Unique team has put together. If you have any questions at all, feel free to ask one of our representatives or give Client Services a call at 1-800-543-4739.

We enjoy hearing from our Clients. If you have a tip, a success story or a question about your pattern, get in touch with us. We love to hear from you!

In Stitches,



Sheri McKillop
Executive Vice President, Unique

Unique Patterns' Mission Statement:
To provide women, no matter what their shape or size, patterns that fit!

History of Unique

In the early '90s, a trend began where women would visit their seamstresses but instead of asking for a garment to be produced, would ask for a pattern that they would then take home and sew up themselves. The basis for these requests was puzzling - why wouldn't these women purchase commercial patterns and alter them? The main reason became apparent; the fit wasn't right and women were tired of altering and re-altering the commercial patterns only to be disappointed with the fit.

This revelation was the foundation of Unique: each and every pattern is drafted specifically to the measurements of the purchaser.

In 1998, the idea evolved to the next level where Clients would not have to take their own measurements - instead they could use a body scanner. The bodyskanner™ quickly captures an accurate set of measurements of a woman's body. The measurements are used by Unique to draft custom-fit patterns.

Unique is continuing to lead the way in revolutionizing the sewing industry and is proud to state that it is the World's Largest Custom-Fit Pattern Company.

Table of Contents

Perception of Patterns	2
An Easy Way to Determine Your Body Code	2
Body Code Chart 2	
Pattern Description	3
Length Adjustments	3
Pant Widths Simplified	3
Making Ease Easy	4
Know your Ease Preference	5
Natural Waist	5
The Virtues of Darts	5
Stitching a Dart	5
The Mysterious Re-appearing Darts	7
Clients' Tips	7
Moveable Darts	8
Fabric Fitting	9
Fabric Choice: Another Reason to Fabric Fit!	10
Fabric Stretches	10
Shoulder Pads	11

Contributors / Sheri McKillop
Joanna Gould-Thorpe
Laura Simmons
Beverly Chapman

Featuring patterns by:

Unique™

Perception of Patterns: The Unique Difference

Your pattern may not be the same shape as the commercial pattern you are used to buying. Your custom-fit pattern will reflect YOU!

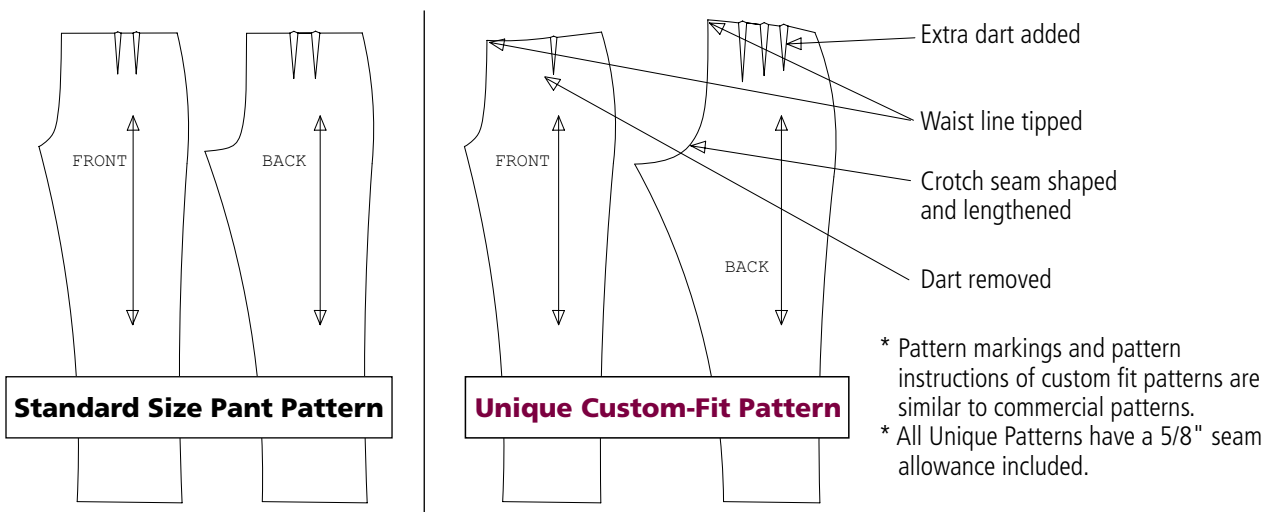

An Easy Way to Determine Your Body Code

Unique uses body codes to help you choose the pattern best suited to your shape. To determine your body shape follow these steps.

1 The easiest way to determine your own body code is to tape a piece of paper on the wall and stand in front of it.

2 Have a friend mark your shoulder points, your waist points and the widest part of your hips. Step away from the paper and, using a ruler, connect the dots to see what shape you are.

3 This example represents an upside down triangle. It is possible to be two shapes ... this may be a triangle leading toward a rectangle. An hourglass figure has equal bust and hips and has a minimum of 10" (25 cm) difference between those measurements and the waist measurement, so this example is less likely to be leading toward an hourglass figure.

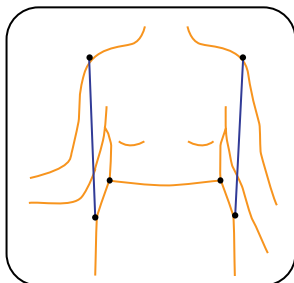
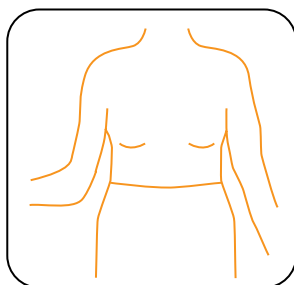

The body code references given with each pattern are merely guidelines; your awareness of what styles of clothes are most flattering on you (helped along by the information you'll learn from "Ease Made Easy") will make your choice your own.

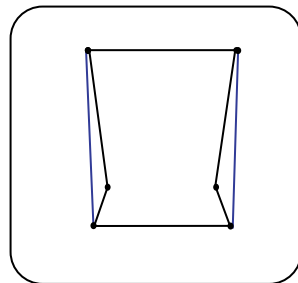

Body Code Chart

- ▼ Broad shoulders and/or a larger bust with narrow hips
- ▲ Narrow shoulders and/or a smaller bust with full hips and/or thighs
- ⌵ Equally proportioned in the bust and hips with a trim waist
- Rounded in the shoulders, arms, bust, waist and hip area
- ◆ Narrow in the shoulders and hips with a fuller waist, wide midriff or upper hip
- Balanced above and below the waist with little or no waist definition

Pattern Description

8003U0

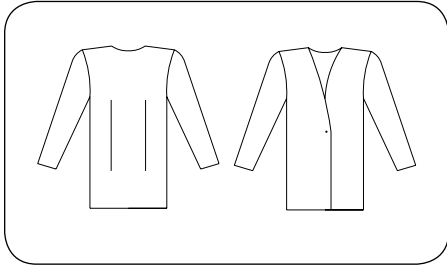

- Body Code:** ▲▼×●◆■ Body Code
- Fit:** semi-fitted Ease
- Ease at Bust:** 5.00 in. (12.75 cm)
- Ease at Hip:** 4.00 in. (10.25 cm)
- Lining:** fully lined Pattern Features
- Neck:** softly tapered V-neck
- Sleeves:** long set-in sleeves
- Bodice Style:** back contour darts
- Closure:** button front Finished Lengths
- Finished Length:** 11" (28 cm) below waist
- Interfacing:** 2 1/4 yd. (2.1 m)
- Notions:** 3/4" (2 cm) shoulder pads, two 1" (25 mm) buttons Notions
- Suggested Fabrics:** linen, med. wt. silk, wool, wool blend Suggested Fabrics

Why the Pattern Description is Important

At Unique we want to give you all the information that you'll need, so that you can choose the best pattern for you. We've developed the pattern description to do just that. Within the description you'll find such things as: the body code symbol; the basic fit category (fitted, semi-fitted, loose fitting, very loose fitting); the ease at bust, waist (if necessary) and hip; style features (we list them in the pattern description because at times these features can be lost in a photograph); finished length (be sure to check this length on you); notions and suggested fabrics (be sure that you choose these fabrics or fabrics that are as similar as possible to the suggested fabrics).

Length Adjustments

Although Unique makes a pattern that is custom-fit to you, we've created a standard for each pattern that we offer. This standard is called the Pattern Description. We acknowledge that every body is unique and that your physique or height may differ from the model for whom the pattern was designed. To that end, we offer finished length adjustments for all our patterns. Contact us for more details.

Pant Hem Widths Simplified

- Narrow leg** = calf measurement
- Tapered leg** = calf measurement plus 1" (2.5 cm)
- Straight leg** = calf measurement plus 3" (7.75 cm)
- Flared/Boot Cut** = see right.
- Wide leg** = from the widest part of your hip the leg will be drafted straight down to hem

A full length pant finishes at the floor in bare feet.

Flared/Boot Cut

A pant pattern stating it has a flared leg will be fitted through the hip (according to the ease stated in the pattern description) and upper leg, flaring out to the degree of flare stated in the pattern description. Flare widths vary greatly and are dependent on the designer's vision. Please check the pattern description before ordering.

Making Ease Easy

Ease is a term that is used frequently; however, it is often misunderstood. Official explanation: Ease is the amount of extra inches drafted into a pattern over and above body measurements. There are two types of ease: 1) Basic ease is the amount added to a pattern for comfort, movement, sitting, standing, eating, breathing etc. 2) Design ease: this is the amount of extra inches designers add to a pattern to create the “look” they want.

Let’s use designers X and Y as examples. Designer X decides he would like to create a romantic, soft blouse so he drafts 12” (30 cm) bust ease to the basic pattern. This is an amount he chooses to create his “look”. Designer Y would like to create a tailored blouse so he drafts only 3” (7.75 cm) over and above the basic pattern. Designer X and Y have both drafted from the same size basic pattern but have added different amounts of design ease. This creates two patterns that fit very differently even if the basic size and design details such as sleeves, collar, and cuffs are similar.

If you have been using standard commercial patterns you have not had the advantage of knowing how much ease is in a pattern before you purchase it. Unique’s patterns let you know the amount of ease before you purchase any particular pattern (the amount of ease for each pattern is stated in the description). For example, when the description says 4” (10.25 cm) ease at bust and 5” (12.75 cm) ease at hips, the pattern, when it is complete, will measure 4” (10.25 cm) more than your bust measurement and 5” (12.75 cm) larger than your hips. If you were to complete this pattern and when standing up pulled all extra fabric to one side of the garment and pinched it, this fabric would represent the amount of ease. So, in this example, if you were able to pinch 2 1/2” (6.25 cm) of fabric to the side of the hip line, you are pinching double thickness which is 5” (12.75 cm) ease.

How are you supposed to know how much ease you prefer? Browse through your closet and find your favorite outfits. Use the provided ease chart to record your preferences. Record your measurements and pay special attention to the fabric used in your garments. Different fabrics have different properties that influence the amount of ease in the finished garment. Many ease preferences can be accommodated during fabric fitting.

Let’s imagine you have made the perfect pair of pants with tweed wool from a pattern with 4” (10.25 cm) of ease at

the hip - perfect for you. So of course, you begin to make this pattern again. This time you choose soft, medium weight rayon. When you finish the pants, you may be confused because the first pair fit perfectly but this pair is “way too big”. What happened? Nothing. Just different fabrics drape differently and require different amounts of ease. The tweed wool was stiff and thick; therefore, the 4” (10.25 cm) allowed at the hips was necessary. They hung straight and in a tailored fashion. The rayon pant appears too large as the rayon hangs softly and moves around your body requiring less fabric to fit over your body. As a rule, stiffer and heavier fabrics require more ease around the body.

If you are trying to make a decision about a pattern’s ease and still have questions, please let us know and we will do our best to help you choose patterns that are suited to your taste. 📖

To Complete Your Personal Ease Chart

1. Choose your favorite garments
2. Measure the garment at the bust, waist and hip
3. Subtract your measurements
4. The remainder number is your ease amount
5. Note the fabric type

You can print this chart from our website.

	Bust	Waist	Hips	Length	Fabric
Jacket					
My Measurement					
My Ease Preference					
Blouse					
My Measurement					
My Ease Preference					
Skirt					
My Measurement					
My Ease Preference					
Pant					
My Measurement					
My Ease Preference					

NOTE: Many ease preferences can be accommodated during fabric fitting.

Know Your Ease Preference

Unique's Fit Chart

In our pattern descriptions, Unique refers to ease allowances at bust, waist and hip. In categorizing the style of garments, we use the following chart:

For **Dresses, Blouses, Shirts, Tops, Vests, Jackets** and **Coats**, each term describes the fit across the bust.

For **Skirts, Culottes** and **Pants**, each term describes the fit through the hips.

Natural Waist

At Unique we use the body's natural waist as a reference from which to determine finished lengths. The natural waist is found in that indent above the hip bone and below the rib cage. Using the pattern description's Finished Length and your natural waist, you can easily see if the finished length will be the best length for you. Many of our patterns state how far below the natural waist the pant or skirt sits.

----- = Natural Waist

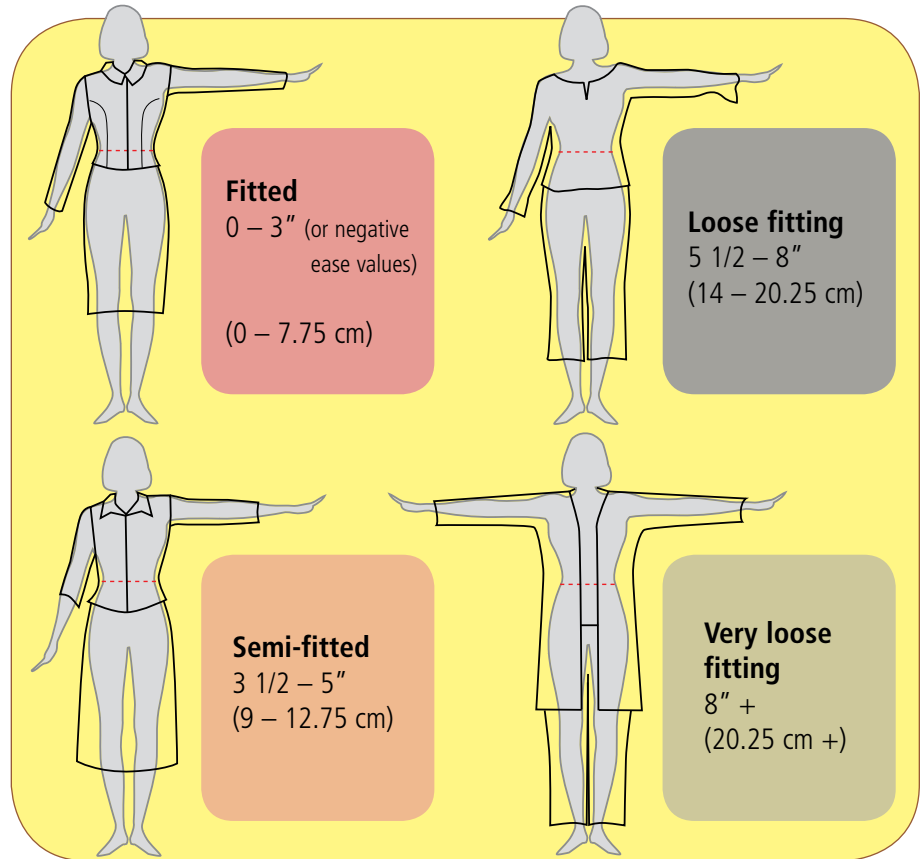

Darts

The Virtues of Darts

Darts are a necessary feature of a well-fitting garment. They allow a two-dimensional piece of fabric to fit smoothly over our three-dimensional bodies. If we were all shaped like cartoon characters after they are run over by a steamroller we wouldn't need darts, but we are shapely with many curves.

On your custom-fit pattern, you may notice darts added even if the original pattern doesn't have them. If you see a dart on your pattern, it has been placed there to enhance the fit around a curved area of your body. The reason many people don't like darts is they are often in the wrong location or aren't stitched correctly and therefore look "homemade". It is important to stitch and press darts accurately, especially bust and waist darts.

Check the location of your darts. Bust darts should point to the bust point and end at least 1/2" (1.25 cm) and up to 2" (5 cm) away from the bust point. Darts on skirts and pants should be located at the fullest part of your tummy or seat and

should never extend beyond the fullest part. Remember that a different bra or panties from the ones you were scanned or measured in can have a dramatic effect. If the darts are in the wrong position, refer to page eight for instructions on moving them.

Stitching a Dart

Darts are always stitched from the widest end to the narrowest end. Contour darts are like double-ended darts and are often found in the waist area of jackets and dresses. They will point toward the bust and toward the hip area. They should be treated as two darts. Begin stitching in the middle of the contour dart where it is

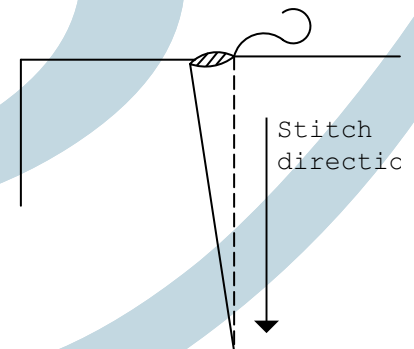

continued from page 5...

widest and stitch to the point. Then begin again at the widest section and stitch to the other point.

Stitch length should be between 10 and 12 stitches per inch or 2.5 mm. When you begin stitching at the wide end you may back stitch to reinforce the end. Follow the line of the dart toward the point. As you approach the point, shorten your stitch length a little to give you more control. As you reach the very end of the point, taper off the edge of the fabric very gradually. Try to aim for taking three stitches at the very end of the dart that are just barely catching one thread of the fabric and then the fourth stitch is off the end. Never backstitch at the point of a dart. This will cause an unflattering bump in the dart from the bulk of the stitches.

There are a couple of alternative ways to secure your threads. Hand tie them in a small knot so the stitches will not come out. This manner is time consuming. Take a couple of stitches on nothing hoping that the threads knot. This method is quick but unreliable. My favorite way is to stitch off the end of the dart, lift the presser foot, pull the fabric away from the needle slightly and then replace it under the presser foot with the bulk of the dart under the needle. Stitch and backstitch in the extra fabric of the dart. A little thread loop will form from the point of the

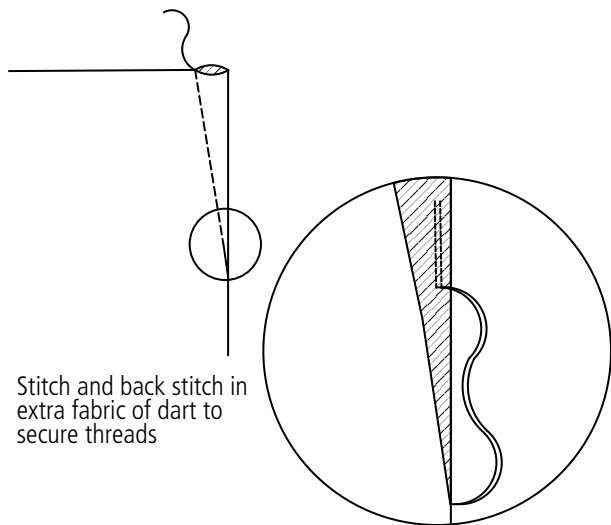

dart to where you back stitch but it is small and inconspicuous. This method is fast and reliable.

Once you have stitched the dart your work is not yet complete. You have stitched a three-dimensional shape into your fabric

and you don't want to take it to the ironing board and press it flat and two-dimensional. Begin by pressing the dart as you just sewed it so the fold line of the dart is pressed. Do not press past the point of the dart. Place the dart over a tailor's ham or rolled up towel moulding the dart to where it fits best. For vertical darts, the bulk of the dart should be pressed toward the center of the garment. For example, skirt darts are pressed toward center front or center back. For horizontal darts like bust darts the bulk should be pressed toward the floor. Carefully press the dart from the wrong side then flip it and give it a finishing press from the right side using a press cloth. If the end of the dart is a little too pointy, place it flat on the ironing board and press just the tip flat to avoid a poke at the end of the dart.

Sewers have often avoided darts because they can make items look homemade, but a dart that is well-stitched and pressed is a great fitting aid that will enhance the look and feel of your garment. 

"That simple "tuck" in the fabric, pointed at one end and called a dart, is a miracle worker."

Palmer/Pletsch Couture, *The Art of Fine Sewing*,
Roberta C. Carr, Palmer/Pletsch Publishing, 1994, pg 69.

Darts are your Friend!

Darts are necessary to shape two-dimensional fabric around a three-dimensional body.

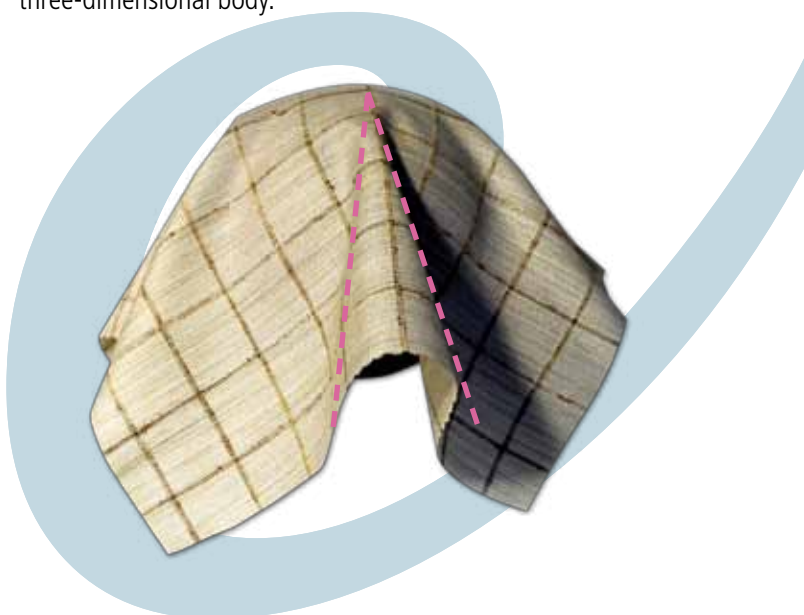

The Mysterious Re-appearing Darts

One of the most common inquiries we have at Unique is from Clients wondering why they have darts when none was shown on the pattern line drawing.

A prime example of this is pattern 4017U0. The line drawing in the catalog shows no bust darts.

When staff member Laura Simmons received this pattern, she immediately went to Unique's director of operations, Joanna Gould-Thorpe, and said, "But it has BUST DARTS!! The line drawing didn't show bust darts!" Joanna's quick reply was, "But you have a bust!"

Joanna went on to explain that it is impossible to take a two-dimensional, non-stretchy material and wrap it around a three-dimensional, bumpy form without removing the excess material in some way. The way that excess is removed from fabric is by adding darts!

In *Fit for Real People*, Pati Palmer and Marto Alto explain, "The bigger the body bumps, the more length, width, and deeper darts they will need."* Only if your body has no curves at all will you be able to smoothly drape a fabric over it with no darts. So, for most of us, we will see that the patterns that are drafted to our measurements will include darts – at the bust, the waist and perhaps the back shoulder.

Another pattern to look at is 4099S2: this pant pattern calls for non-stretch fabrics and has a flat front.

The only way that this pattern will come to you with the front flat (i.e., no darts) is if YOUR front is totally flat. If you have a tummy at all, darts will be added in order to keep the ease of the pant waist in the proper relationship to the ease of the hip. If the darts are left out, and your front is not flat, the pants will be either too large in the waist (to fit the hip ease) or too tight through the hips (to satisfy the waist ease). Revisit the article "Making Ease Easy" which helps you decide what style of clothes suit you best.



4017U0
US\$15.99
CDN\$21.59

Whenever Unique adds a dart where one was not shown in the line drawing, a notation will be printed on the pattern.

Our desire is to make your clothes fit you properly: to accomplish this, many of our patterns will include darts to make your fabric lie smoothly against your curves. 

*Reprinted with permission from:
Fit for Real People, Pati Palmer and Marta Alto,
Palmer/Pletsch Publishing, 1998, pg 141.

Clients' Tips

On Marking Your Pattern....

Because the paper that my Unique pattern is printed on is so sturdy, I can't see through it. Before I use my patterns, I take them to my ironing board and use a pin to poke holes along the dart lines, grainlines and other markings. That way, if I turn the pattern upside down for cutting my fabric, I can still see all the markings.

Beverly Chapman-Burse / Lower Sackville, Nova Scotia

On More Accurate Cutting....

Here's a tip regarding lightweight clear vinyl. I bought a metre (1 1/8 yds.) of it and laid all my quilting rulers on it. With a rotary cutting mat underneath and using my utility knife, I cut around each ruler. The vinyl sticks to the backs of the rulers and keeps the rulers from slipping when you cut strips or squares of fabric. You don't have to use an adhesive to get the vinyl to stick, just pat it into position with your hand and the static makes it cling to the ruler.

Rosemarie Menassas / Abbotsford, British Columbia

On Marking Your Garments....

When I make elastic waist slacks or a skirt, I find it's hard to tell the front of the garment from the back. I make my own 'GPS' (Global Positioning System) by cutting a 2 1/2" (6.25 cm) length of lace seam binding (but even a ribbon would work) and sewing it into the back casing as I am putting the elastic in. Voilà! Instant navigation to tell the front from the back of the garment as I quickly get dressed in the morning. And the lace adds a nice touch!

Barbara Heathcote / Raleigh, North Carolina

On Sewing Hems....

When sewing hems into any garment, sew with the grain. In other words:
Start at the center of the skirt bottom (dress or pants) and hem to the side. Start over again at the center of the skirt and sew to the opposite side. Do the same for the back of the garment.

You will have a perfect hem...no puckers.

Jan Squires / Ocala Chapter ASG / Beverly Hills, Florida

Moveable Darts

Some of our patterns offer instructions on how to move darts. This may seem odd when you've had the patterns drafted to your, and only your, measurements. The reason Unique gives you these instructions is related to your undergarments.

Undergarments tend to lose their support as they age. If you were scanned wearing an older bra, your bust point may be in a different position than with a new version of the same brand of bra. If you switch the style of bra you wear or even tighten the bra straps, you may also have to modify the dart's placement.

Perhaps now you've chosen to make a 'little black dress' to wear for special occasions and you know that you'll be wearing

a perkier bra; the point of the dart over the new bra will be different than the point of the same dart over your regular bra. So, you will have to re-position the darts. The "Virtue of Darts" on page five explains the proper positioning of darts.

As we age, gravity begins to tug on body parts. Most of the body parts that are affected by gravity are the same parts that require darts. Your measurements may be essentially the same, but your curves may follow a different line as you get older. The darts must move to accommodate the new location of these curves.

Following our instructions, moving darts is a simple task that will benefit the fit of your garment, regardless of bra style, age or garment choice. 🧵

Darts

Instructions on How to Move Darts:

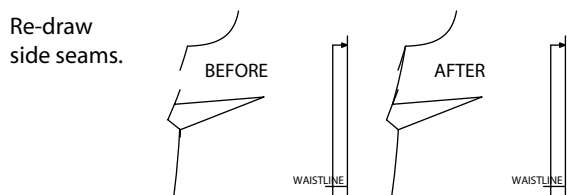
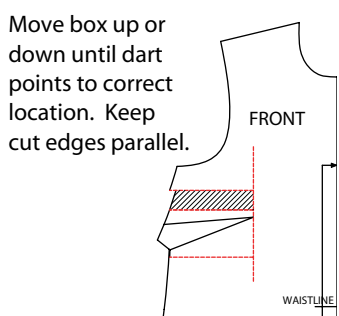
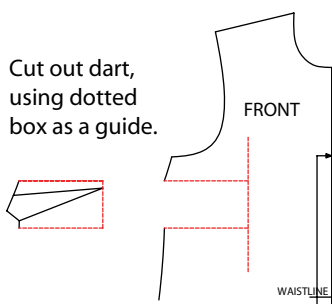

For styles with Contour Dart

When adjusting bust dart, position it up or down.

End of contour dart needs to be adjusted the same amount/direction as bust dart.

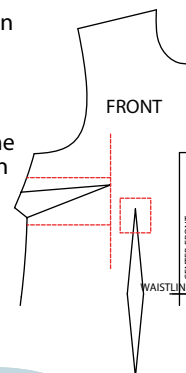

Measure the amount the bust dart was moved. From the top end of contour dart mark new position. Re-draw contour dart.

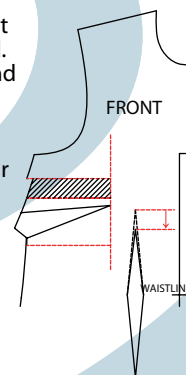

Fabric Fitting

If every garment were made out of the exact same fabric AND you never lost or gained pounds AND gravity didn't play a factor AND you liked the exact amount of ease a pattern came with, then you could sew your pattern together from start to finish knowing it would fit the same every time. Wouldn't that be boring? We all like to use fun fabrics, varying weights, embroidery designs and embellishments to have garments that look different each time. Not to mention, some of us would like to lose a couple of pounds before we sew the pattern. Fabric fitting allows you to do all of this with the confidence that your garment will fit.

When a pattern is custom-fit to your measurements, Unique knows two things: the amount of ease in that particular pattern and your measurements. This allows us to draft patterns to fit your body. What we don't know is what kind of fabric you will sew with. No one can know exactly how the fabric you choose will react with the pattern custom-fit to your measurements. That is why every garment requires fabric fitting. You're probably thinking to yourself, if I have to fabric fit, why did I pay for a custom-fit pattern? Good question! As Marta Alto says, "we take 90 per cent of the fitting out of your hands. The remaining 10 per cent depends on you".

Fabric fitting is not a time-consuming or knowledge-intensive procedure. It simply means trying on the garment at different stages of construction to see how the fabric is draping considering your pattern style and body shape. The adjustments you make will be minor and only require some pins and a marking pencil.

How to fabric fit? To begin fabric fitting, cut the pattern out of your fashion fabric. Pin the major seams, wrong sides together, with pins in the seam line parallel to the cut edges. Remember to pin darts. Try the garment on with the fabric right side out. This is very important to remember if you have left and right side differences. The seam allowances will be on the outside. You can now fabric fit your garment by pinning the seams deeper or

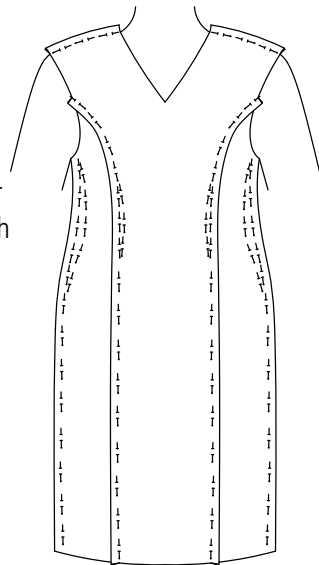

shallower to accommodate different fabrics, ease preference, minor weight fluctuations and different undergarments. Some styles may be more flattering if you take them in or let them out a little here and there.

Remove the garment. Mark only the changed pin positions by opening seam allowances and marking the pin on the wrong side of the fabric. Re-pin with right sides together and stitch using a 5/8" (1.6 cm) seam allowance and the chalk markings as your stitching line.

Sheri's Method

I find that I can actually stitch the garment together faster than pinning, so when I fabric fit, I stitch my seams with a basting stitch. I stitch with right sides together, as I have no left and right side differences. I proceed to pin where necessary and mark the pin placements. I can then stitch over my basting stitches or remove them quickly to adjust. If your garment has many darts and design lines that would require a lot of pinning, you may find my method works faster.

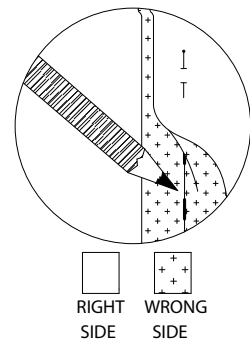

Now you have the freedom to sew your patterns out of numerous fabrics and have a beautifully fitting garment. 🧵

In the Sew News article, Top 10 Fitting Tips, Mary Roehr writes:

The same pattern made in different fabrics won't fit the same. Spending time perfecting one basic pattern won't guarantee a perfect fit every time. Fabric weight and construction affect fit. It's great to begin with a favorite pattern, but realize that heavy fabric takes up more space. You'll have to make a garment bigger if you originally made it in light- to medium-weight fabric and vice versa.

Reprinted with permission from the September 2004 issue of Sew News. Visit www.sewnews.com

Fabric Choice: Another Reason to Fabric Fit!

These two jackets are made from the same pattern.

The jacket on the left is made from mid-weight wool tweed and hangs quite straight.

The jacket on the right is made from heavy-weight faille and drapes softly.

Fabric Fitting



- These photos show how different fabrics
- will sew up into totally different garments.
- even when the pattern is the same.

We know your pattern, we know your measurements. We don't know your fabric choice. Be sure to fabric fit!

Fabric Stretches!

We're all great proponents of fabric fitting, but there is one thing we have to remember when we're fitting our pants or skirts ... fabric stretches!

Because our bodies have curves, the waist of our pant and skirt patterns will quite often be curved. Those curves on the pattern mean there will be curves cut in your fabric, and any time fabric is cut on a curve or any angle of bias, it will stretch. So, as we're wiggling our pant or skirt (with no waistband) over our hips to fabric fit it, we're stretching the top of the fabric where it is cut on the curve. When we try to fit the waistband onto the garment, the waistband seems too small because we've stretched the pant fabric. This can be a problem.

The best way to deal with this problem is to prevent it in the first place. How this is accomplished will depend on how you prefer to fabric fit your garment. If you like to baste your seams first, the waist will have to be stabilized. **(fig. 1)** Simply baste stay tape, twill tape or even some scrap selvage

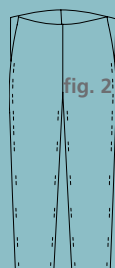
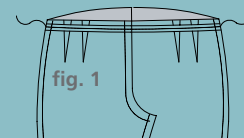

edge of fabric along the seam line; this will prevent the fabric from stretching out of shape during fabric fitting. If you like to pin your seams for fabric fitting, leave the outseam edges unpinned from the widest part of the hip up until you have stepped into the pants or skirt **(fig. 2)**; pin to fit, mark your seams and un-pin the side seams to step back out of the garment.

If the fabric has already been stretched, the pants or skirt will need to be eased back into the waistband.

Run one line of basting along the seam line where they will be attached to the waistband and pull up the bobbin thread in the areas where there is excessive stretch. Be sure to match the markings on the waist edge with the markings on the waistband **(fig. 3)**. Press the finished garment thoroughly so the easing will not be noticeable.

Fabrics that stretch most during the fabric fitting stage are those with a lot of crosswise give such as a loose linen, linen blend and rayons. Fabrics with stretch built into them, such as stretch wovens, will bounce back into shape more readily, but should still have the waist seam stabilized.

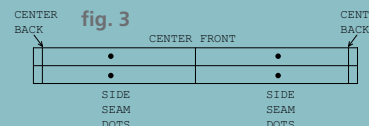

With a little extra care, you can fabric fit your pants or skirt and have the waistband fit perfectly every time! 

Shoulder Pads

When we're looking for a short cut, either in terms of time or money, sometimes we're tempted to skip the shoulder pads.

Don't do that!

If you reach up and slide your hand from your shoulder down towards your chest, you will most likely find a hollow space under your hand. Concave surfaces such as this don't allow fabric to lie flat. Unique's educational material will explain that we insert darts to allow for curves, or deepen the darts that are already there, so fabric can lie flat. But the shoulder front area is not a pretty place to put a dart. The way to eliminate draglines on the front of a jacket is to insert shoulder pads.

Shoulder pads can also be used to balance out some of your physical features. By adding shoulder pads, you can minimize larger arms and bust lines and make hips look slimmer. The placement of the pads within your garment can mask a sloped shoulder that rotates forward. If one shoulder is higher than the other, shoulder pads of different sizes can even them out.

There are two types of shoulder pads: dropped shoulder pads and set-in sleeve shoulder pads. Dropped shoulder pads are for garments with dropped, raglan, kimono, capped and dolman sleeves. This type of pad has a sleeve head built onto it so it will fit over the curve of your arm. Set-in sleeve shoulder pads are for garments with an armhole seam placed at or close to your arm hinge. These are the most common type of shoulder pads and come ready-to-use in a variety of sizes and thicknesses.

The success of the fit in the shoulder area of your jacket depends not only on the inclusion of shoulder pads, but also on the way that the shoulder pads are placed. With set-in sleeves, be sure the seam allowance is toward the sleeve. Before you add the lining, try the garment on in front of a mirror and pin the shoulder pads in place from the outside of your garment, positioning the shoulder pads individually so that they are symmetrical and balanced. The pads should extend into the armhole from 3/8" to 5/8" (1 - 1.6 cm) beyond the seam line, depending on the garment style and your personal preference. Then hand stitch the pad from the inside of the jacket to the shoulder seam allowances. Do not bend the shoulder pad out of its natural shape. If you prefer, you can also lightly whip stitch the shoulder pad to the seam allowance of the sleeve cap.



Shoulder Pads vs No Shoulder Pads

Commercial, ready-to-use shoulder pads come in standardized sizes. If not all commercial patterns fit all body shapes, it makes sense that not all shoulder pads will fit all garments. Unique has the perfect solution: when you order a pattern that requires shoulder pads, you can, for a nominal fee, request a custom-drafted shoulder pad pattern that is drafted specifically from the upper body pattern that you ordered. You'll know that the shoulder pad will fit properly into the curve of the garment.

Whether you are going to purchase shoulder pads from your local sewing and fabric store or make your own from our custom-drafted pattern, shoulder pads are an essential element of every jacket. If the pattern calls for shoulder pads, using them properly will help you successfully achieve a professional-looking garment. 🧵

Our **Client Services Consultants** are here to help you with all your inquiries. If you are phoning about a Unique pattern, or a garment you've made from a Unique pattern, you will be asked some standard questions:

- Have you read your Guide to Fit?
- Have you reviewed your measurements? (available on-line or printed on the pattern)
- Have you sewn your garment?
- Did you use the suggested fabrics? What fabric did you use?
- Did you fabric fit? Was fabric fitting helpful?
- Can you describe the issue you are encountering?
- Can you provide digital photos?

At Unique, our goal is to provide you with the best fitting garment possible!

Call **Client Services** at **1-800-543-4739**.

Remember to Fabric Fit!

All you need to know and more - visit the Unique Patterns website!

www.uniquepatterns.com

As a Client of Unique Patterns, you can log in and have access to lots of great information!

- Education
- Online Catalog
- Tip of the Month Archives
- e-Newsletters
- Current Promotions
- Latest Additions
- Body Scanner Events
- Your Membership Information

Unique Patterns
15010 Henry Ride Heights
Colorado Springs, CO
80926 USA

Phone: 1-800-543-4739

Fax: 1-800-543-4739

Record your Client Number:

_____ and password (password is telephone#):

Other important information to remember:

Client Services: 1-800-543-4739.

Toll-free fax number: 1-800-543-4739

E-mail: clientservices@uniquepatterns.com

Moving or changing internet providers?

You can update your own contact information! Sign into **www.uniquepatterns.com** and choose "My Profile".